

CR2 3.0V LITHIUM BATTERY

EU-CR2-850MAH

Temperature characteristics

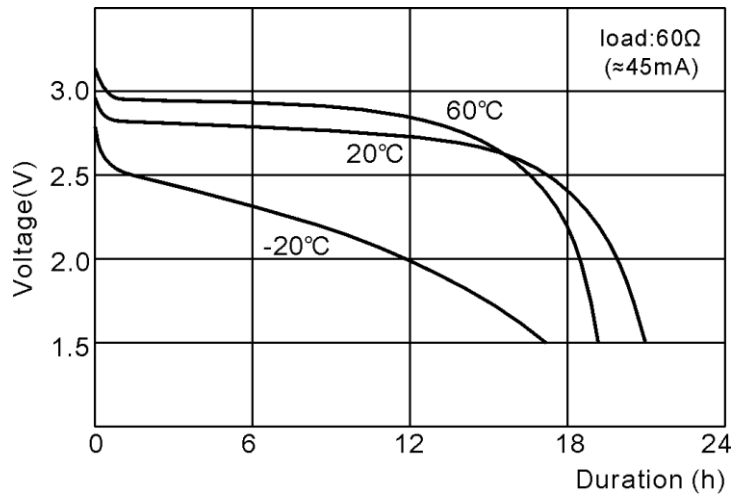
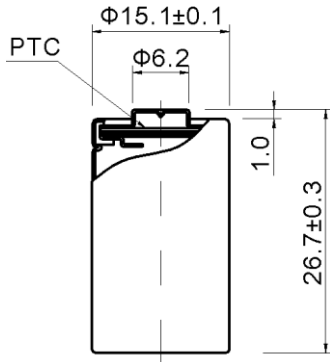

Pulse discharge characteristics

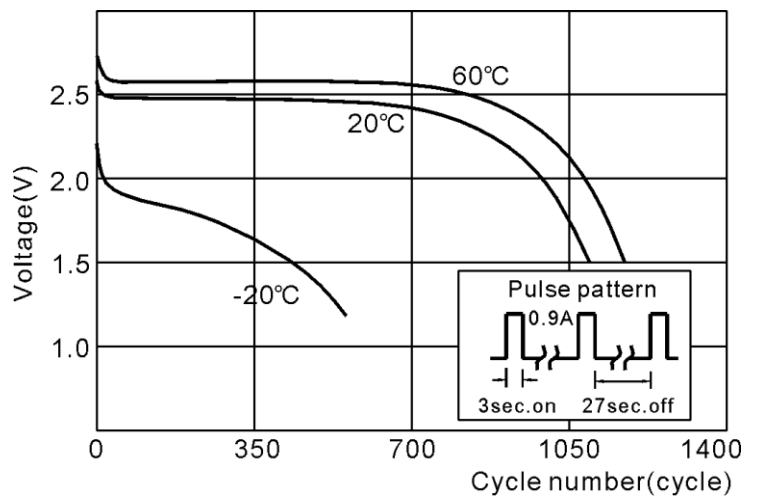

Model	CR2
Nominal Voltage	3V
Nominal Capacity	850mAh
Dimension	Φ 15.1 × 26.7mm
Weight	10.2g
Temperature range	-30~60°C

Typical discharge characteristics

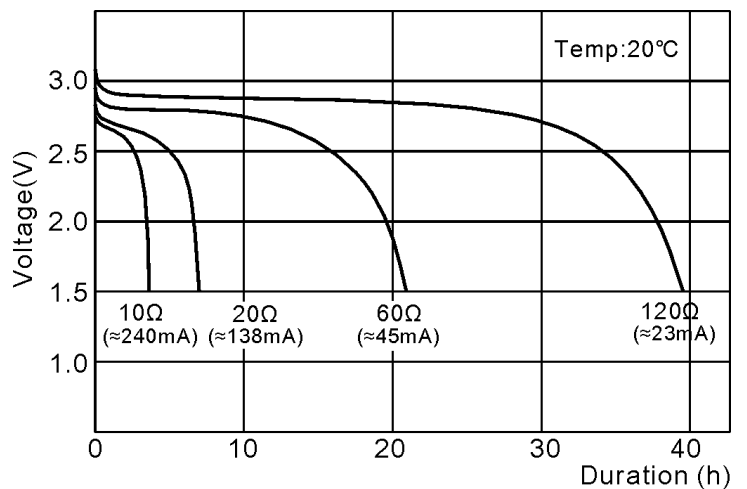

Eunicell®
Batteries

EAST(SHENZHEN)TECHNOLOGY CO.,LTD

1. Model Number : CR-2
2. Nominal Voltage : 3 V
3. Nominal Capacity : 850 mAh
(Nominal capacity is based on standard drain and cutoff Voltage down to 2.0V at 20°C)
4. Standard Discharge Current : 20 mA
5. Max. Continuous Discharge Current : 1000 mA (at 20°C)
6. Construction
 - 6.1 Appearance, Dimensions : There shall be no noticeable deformation.
The dimensions shall be according to the attached drawings.
 - 6.2 Weight : Approx. 10.2g
7. Performance
 - 7.1 Open Circuit Voltage : Min. 3 V
 - 7.2 Duration 1. (at 20±2°C)
 - 7.2.1 Pulse Discharge Conditions : Population Mean ≥ 950 cycles
 - Pulse Current : 900 mA
 - One Cycle : 3 seconds on, 27 seconds off
 - Cut Off V. : 1.55 V
 - 7.2.2 Max.Pulse current :3000mA
 - 7.3 Duration 2. (at -20±2°C)
 - 7.3.1 Pulse Discharge Conditions : Population Mean ≥ 500 cycles
 - Pulse Current : 900 mA
 - One Cycle : 3 seconds on, 27 seconds off
 - Cut off V. : 1.2 V
 - 7.4 Impedance : Max. 1.0 Ω
 - 7.5 Vibration Resistance : Deterioration of performance shall not occur.
 - 7.6 Temperature Range : Discharge -30 to 60°C
Storage -30 to 60°C
 - 7.7 Leakage Resistance : The battery shall not show leakage or salting which harms performance.
8. PTC (Positive Temperature Coefficient) Device Performance
 - 8.1 Appearance : There shall be no noticeable deformation and/or scratches.
 - 8.2 Resistance : The resistance shall be between 15 to 80 mΩ (no load).
When 5 A flows, the resistance shall be more than 10 Ω before 80 seconds.
9. Test Conditions, Measuring Instruments and Measuring Methods
 - 9.1 Test Conditions : If not otherwise specified,
Temperature : 25±5°C
Humidity : 65±10%
 - 9.2 Measuring Instruments
 - i) Volt Meter : Internal Impedance : More than 10MΩ
Accuracy : Less than 0.5%
 - ii) Battery Impedance Meter : Sine wave A,C,method ; 1 kHz 0.1mA
(National Digital milliohm Meter [VP-2811A])

EAST(SHENZHEN)TECHNOLOGY CO.,LTD

- iii) Caliper : Accuracy ; less than 1% by JIS
- iv) Balance : Sensitivity ; More than 100 mg
- v) Ohm Meter : Sine wave A.C.method ; 1 kHz 0.1mA
(National Digital milliohm Meter [VP-2811A])

9.3 Measuring Method

- i) Outer Dimensions : This shall be measured with the caliper described in Item 9.2 iii).
- ii) Weight : This shall be measured with the balance described in Item 9.2 iv).
- iii) Appearance : Deformation or tarnish shall be visually checked.
- iv) Open Circuit Voltage : This shall be measured with the volt meter described in Item 9.2 i).
- v) Operating Time (Duration) : Operating time shall be measured with cycles until terminal voltage reaches the specified cut-off voltage.
- vi) Battery Impedance : This shall be measured by the meter described in Item 9.2 ii).
- vii) Vibration Resistance : Amplitude ; 2 mm
Number of Vibrations : 1000 rpm.
Directions ; X,Y,Z
Time ; 30 minutes in each direction
- viii) Leakage Resistance : Heat cycle test
Leakage, appearance and outer dimensions shall be checked after 10 cycles according to MIL-STD-202E-106D.
The battery shall be kept in a dry place. It should not show any dew point when stored in this condition.
- ix) PTC Device Performance : This shall be measured with the instrument described in Item 9.2 v).

10. Precautions for use

- 1) A battery shall not be stored at temperatures in excess of 45°C. Storage at less than 30°C is recommended. Storage at less than -30°C can deform the plastic parts and may cause a leakage. To prevent self-discharge caused by corrosion, or decrease of insulation, humidity during storage shall be less than 70%.
- 2) The battery has an explosion resistant construction. But the following cautions should be taken. because combustible materials such as lithium metal and organic electrolyte are contained in the battery.
 - * Do not short circuit.
 - * Do not dispose in fire.
 - * Do not charge.
 - * Do not disassemble.
- 3) Keep away from heat source of flame.
- 4) The battery shall not be washed by ultrasonic wave washer.

This data is subject to change. Performance information is typical. Contact Eunicell for the latest information.